

Union ball valve

Fig.120D : Degreased for Oxygen



www.coreline.dk

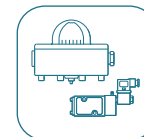
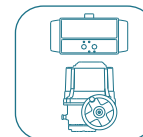
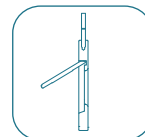
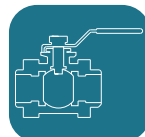
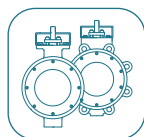
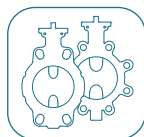
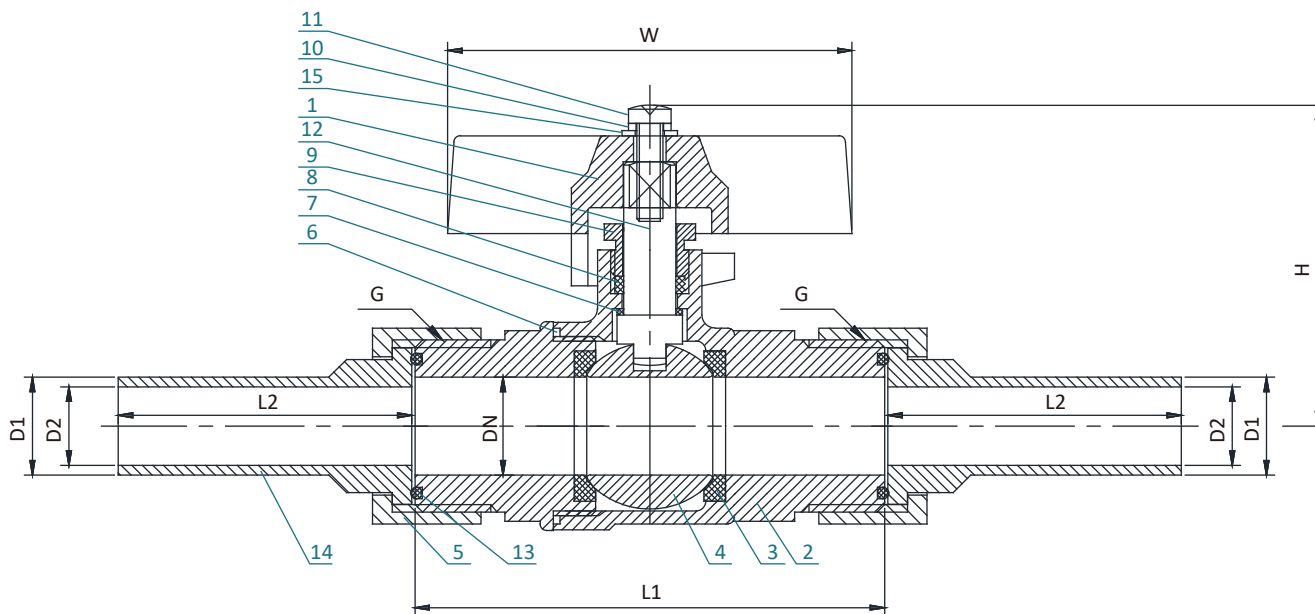

Fig.120D union ball valve - Degreased for Oxygen



Material part list

NO.	NAME	MATERIAL	QTY	NO.	NAME	MATERIAL	QTY
1	HANDLE	CF8M	1	9	GLAND NUT	304	1
2	BODY	CF8M	1	10	SPRING WASHER	304	1
3	BALL SEAT	PTFE	2	11	BOLT	304	1
4	BALL	316	1	12	STEM	316	1
5	NUT	CF8M	2	13	O-RING	VITON	2
6	END SEAL	PTFE	1	14	CONNECTING JOINT	316L	2
7	THRUST WASHER	PTFE	1	15	WASHER	304	1
8	STEM PACKING	PTFE	1				

Dimensions

INCH	DN	D1	D2	L1	L2	H	W	G
1/2"	15	15	12	72	45	49.2	62	G3/4"
1"	25	28	25	100	60	61.5	62	G 1 1/4"



CORELINE VALVE CO., LTD.

Add: No.210 Xinyuan Road, Ehu Industrial Park, 214116 Wuxi, China

The contents of this catalogue are confidential and proprietary to Coreline, we reserve the right to change the specifications without any notice.

Phone: +86 510 8852 5336

Http: // www.coreline.dk

E-mail : mail@coreline.cn