

3pc Ball Valve 三片式球阀

Fig.130,131
Fig.135

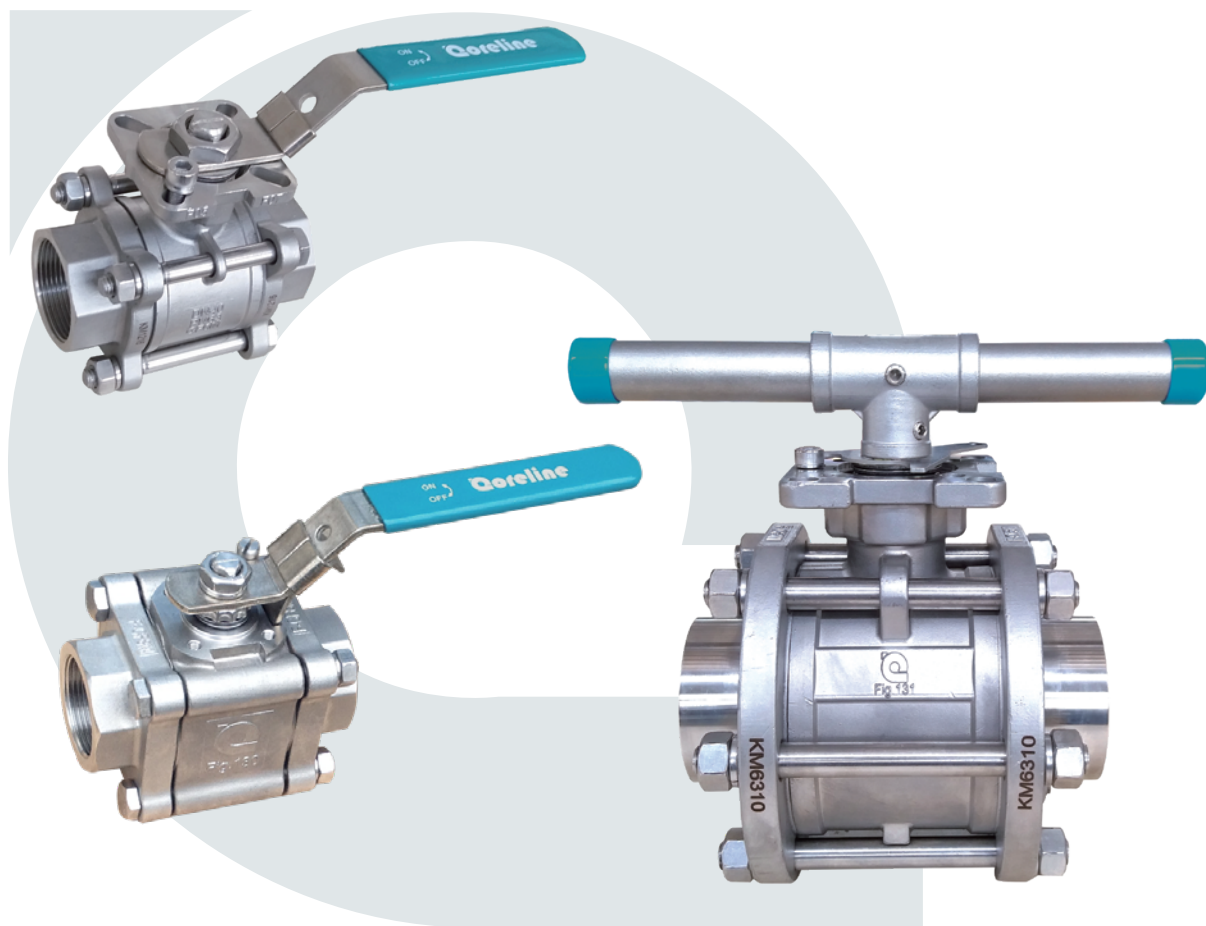

ATEX, CE, SIL and EU1935/2004 (European food approval) for Coreline ball valves.
Coreline球阀拥有ATEX, CE, SIL以及EU1935/2004欧洲食品级认证。

www.coreline.dk

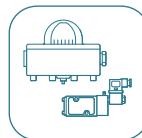
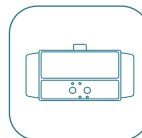
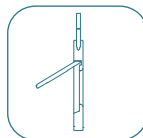
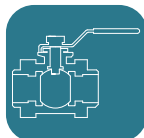
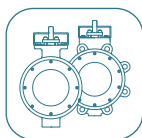
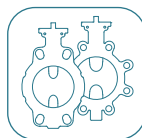



Fig.130



Fig.131



Fig.135

Pipe preparation 管道预备

- Make sure the pipeline is correct. Tensions and displacements in the pipeline may cause high torque value and leakage between the body and end caps. 确保管道安装无误。管道中的张力和偏移可能会导致阀门扭矩值偏高、阀体和端盖之间泄漏。
- The pipeline should be supported and the space between the pipe endings must correspond to the face-to-face dimension of the ball valve. 管道应有足够的支撑，并且待安装的管道两端的距离必须与球阀的结构长度相符。
- Foreign matters in the pipeline may damage the sealing surface of the valve or prevent the movement of the valve ball, resulting in the valve not closing properly. In order to reduce the possibility of dangerous situations, all pipes need to be cleaned before installing the valve. Check that pipe dirt, metal chips, welding slag and other foreign objects have been removed. In addition, check the flange surface of the pipe to ensure that there is a smooth surface (If any cleaning proces after the valve is installed in pipeline, the ball valve has to be in open position and must not be activated before rinsing completed, to avoid damage of seat). 管道中的异物可能会损坏阀门的密封面或球阀堵死，导致阀门无法正常关闭。为了减少此类情况发生，所有管道都必须在安装阀门之前进行彻底清洗以清除了管道上的污垢、金属焊渣和其他异物。如果将阀门安装在管道中之后进行任何清洁，则球阀必须处于完全开启状态，并且在冲洗完成之前不得启动球阀，以免损坏阀座。

Operation and use 操作和使用

- This guide contains information concerning the installation, operation, and storage of Coreline 3PC ball valves. To ensure efficient and safe operation of Coreline 3PC ball valves, the instructions in this manual should be thoroughly read and understood. This manual is general in nature and is not meant to take the place of an on-site, process engineer or pipe fitter. As such, Coreline recommends that only experienced, skilled personnel be allowed to install and maintain Coreline 3PC ball valves. Please retain this manual in a location where it is readily available for reference. 本指南包含有关Coreline三片式球阀的安装、操作和存储的信息。为确保Coreline三片式球阀的有效和安全操作，应通读并理解本手册中的说明。本手册本质上为通用手册，不能代替现场、工艺工程师或管道安装工。因此，Coreline建议仅允许有经验的技术人员安装和维护球阀。请将本手册保存在便于参考的位置。
- The opening and closing of the valve is done by turning the handle a quarter turn (90° turn). 在阀门全开或全关位置时，90° 旋转手柄以完全关闭或完全开启阀门。
The valve handle is marked showing proper rotation direction for "ON" and "OFF" positions. Rotation is clockwise for "OFF" (closed) and counterclockwise for "ON" (open). 阀门手柄套上印有“ON”及“OFF”标记。顺时针操作手柄阀门“OFF关闭”，逆时针操作手柄阀门“ON开启”。



- Valve in OPEN position: The handle is in line with the valve or pipeline. 阀门处于“ON”全开位置时，手柄与阀门流通方向平齐。
- Valve in CLOSED position: The handle is across the pipeline. 阀门处于“OFF”完全关闭位置时，手柄与阀门流通方向垂直。
- The use of the valve shall be carried out in accordance with the instruction manual, and shall not exceed the design parameters. The operator must go through on-the-job training to understand the basic operation principle of the valve. Prevent incorrect opening and closing of valves. The operator should clearly understand the role of each valve and its position in the process pipeline to prevent misuse. It should be ensured that the valve can be opened and closed at least twice within a week to prevent the valve from being stuck due to long-term inactivity. 阀门的使用应按照说明手册进行，并且不得超过设计参数。操作人员必须接受专业培训，了解阀门的基本操作原理，从而防止错误地操作阀门。操作员应清楚地了解每个阀门在过程管线中的位置及作用以防止误操作。应确保在一周内至少可将阀门打开和关闭两次，以防止由于长期不活动而使阀门卡死。

Installation guide 安装指导

- Coreline 3PC ball valve can be installed in any position on the pipeline, but be aware that deposited dirt in the bottom of the pipeline may damage the stem seal if the valve is mounted upside down. Coreline三片式球阀可以安装在管道上的任何位置。但请注意，如果阀门倒置安装，则管道底部的沉积污垢可能会损坏阀杆密封件。
- The ball valve shall be installed minimum 6 pipe diameters from sources of turbulence (See Fig.1). Coreline三片式球阀应该安装在距离湍流源至少6倍管道直径的位置（如Fig.1）。

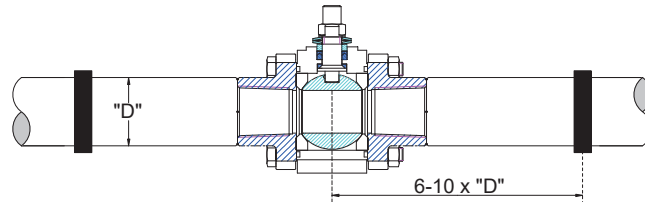

Fig.1

Installation of thread ends ball valve 三片式螺纹球阀的安装

- Do not disassemble the valve before installation. 安装前请勿拆卸阀门端盖。
- Sealant is applied to the pipe thread (Packing yarn, Teflon tape etc.). 螺纹连接位置需使用合适的螺纹密封剂或生料带等来确保密封。
- Apply wrench only to the hexagon part of the valve end that is to be connected. 在安装阀门过程中，仅在连接端的阀体六角上使用扳手固定拧紧。

Installation of weld ends ball valve 焊接端球阀的安装

- Align the open ball valve between the pipes and spot weld four places on each weld connection end. 将全开的球阀至于管道之间，并在每个焊接连接端的四个合适的位置进行点焊。

Welding for Fig.130/131: Fig.130/131球阀的焊接

- The valve should not be separated during TIG welding. Keep the valve in open position and complete the welding process (See Fig.2). TIG焊接时不应拆卸阀门端盖。保持阀门处于开启状态并完成焊接过程（见Fig.2）。
- With the ball valve open flush the pipes. 保持球阀完全开启，再彻底冲洗干净管道。

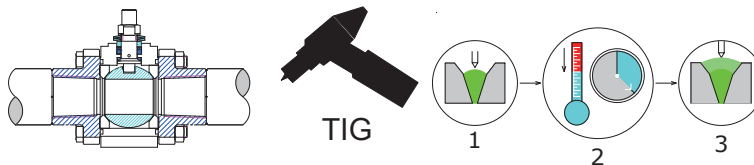

Fig.2 Welding for Fig.130/131

Welding for Fig.135: Fig.135球阀的焊接

- With the ball valve open, disassemble the body from the spot welded connection ends and place the body in a clean and safe place (See Fig.3). 在球阀打开的情况下，拆除阀体螺栓，将中间阀体部分取出放置在干净安全的地方。

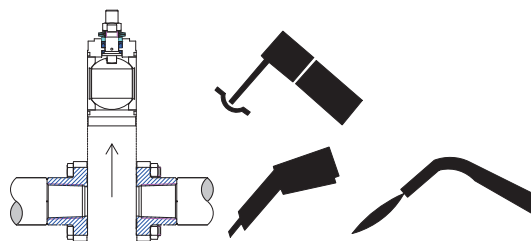
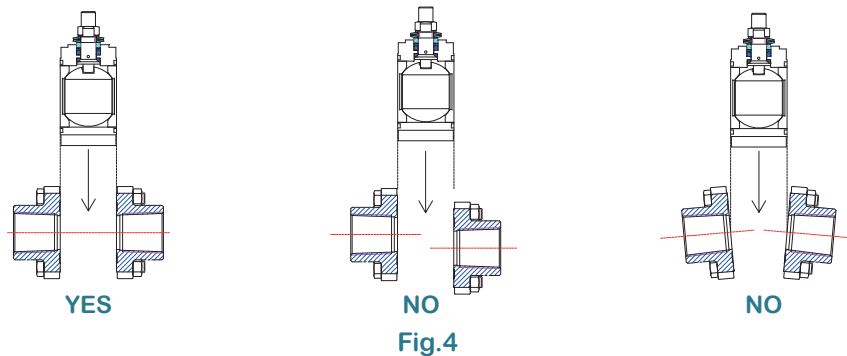

Fig.3 Welding for Fig.135

- Make sure that the connection ends are aligned. Complete the welding of both connection ends to the pipe. Carefully place the open ball valve (body) between the cleaned and cooled connection ends. Make sure that the joint gasket is not scratched against the connection ends, which may cause leakage during operation (See Fig.4). 确保需焊接的两部分阀门端盖对齐并同心，再完成连接端盖与管道的焊接。再小心地将开启的球阀阀体中间部分放置在经过清洗和冷却的两端盖之间。在操作过程中，确保阀体密封线及接触端面不得损伤，以免造成阀门泄漏。
- With the ball valve open carefully tighten the bolts evenly in a star pattern with a torque wrench under the given torques by Coreline. 在球阀打开的情况下，用扭矩扳手在Coreline给定的扭矩下以星型形式均匀均匀地拧紧螺栓。
- With the ball valve open flush the pipes. 保持球阀完全开启，再彻底冲洗干净管道。



Ball valve function test 球阀功能测试

□ Gradually open and close the valve until a full 90° turn is obtained. In this way you make sure that the seat is shaped against the ball. This is particularly important when installing new seats. 缓慢开启和关闭阀门，此过程保证阀门从开至全关旋转完全90度。此过程可以确保阀座紧贴球阀。在安装更换新阀座后，此操作尤其重要。

Valve tests 阀门测试

Make pressure test and torque test of a re-assembly valve prior to place it back into pipeline. 将出厂后重新组装的阀门安装在管道中之前，需先对其进行压力及扭矩测试。

□ Fix the valve on the pressure test machine with proper toolings. Orient valve so seat to be tested is facing upwards. 使用合适的工装夹具将阀门固定在压力试验机的工作台上。调整阀门方向，使要测试的阀座面朝上。

Pressure test 压力测试

□ Introduce 6bar air. Carefully operate the valve under the given air pressure, and then slowly close to make sure the cavity is pressurized. Put water into the upper port to cover the ball and then visually check if there are bubbles. If bubbles appear, pour water out and then operate the valve several times and recheck. Reverse the valve and put air pressure to the port just checked to check for leakage in the other port. 引入6bar气压。在给定的气压下小心操作阀门，然后缓慢关闭以确保腔体受压。将水倒入阀门上端口使其覆盖球阀，然后目测是否有气泡产生。如果出现气泡，请倒出水，然后开关操作阀门几次，再重新检查按照上面提到的方法再次进行低气压密封检查。将阀门旋转180度，向刚检查过的端口施加气压，以检查另一个端口是否有泄漏。

□ Check stem seal by covering the stem top area with water/soap solution. Tighten stem seal if leakage occurs until leakage just stops. 通过用水/肥皂溶液覆盖阀杆顶部区域来检查阀杆密封。如果发生泄漏，则拧紧阀杆密封件，直到泄漏停止为止。

□ Apply a water pressure test according to API598. 根据API598标准对阀门进行水压试验。

Valve torque test 阀门扭矩测试

Coreline Fig.130/131/135 ball valves are applied with below torques (See below Table) when the valves are delivered.

Coreline Fig.130/131/135球阀交付时，扭矩如下表。

| Size | Torque [Nm] ¹⁾ | | | Size | Torque [Nm] ¹⁾ | | |
|---------|---------------------------|-----|-----|----------|---------------------------|-----|-----|
| | 135 ²⁾ | 130 | 131 | | 135 ²⁾ | 130 | 131 |
| 8F | - | 6 | 8 | 40F/50R | 26 | 35 | 35 |
| 10F/15R | - | 6 | 8 | 50F/65R | 36 | 48 | 49 |
| 15F/20R | 8 | 9 | 8 | 65F/80R | 53 | - | 68 |
| 20F/25R | 10 | 16 | 14 | 80F/100R | 70 | - | 101 |
| 25F/32R | 17 | 22 | 18 | 100F | 120 | - | 124 |
| 32F/40R | 24 | 27 | 28 | | | | |

1) Torque values include 30% safety factor (Test: 0bar differential pressure, ambient temperature, non-lubricating). 扭矩值包括30%的安全系数（测试：0 bar压差，环境温度，无润滑）。

2) Fig.135 ball valve are all with full port design. Fig.135球阀设计为全通径。

Coreline

The contents of this catalogue are confidential and proprietary to Coreline, we reserve the right to change the specifications without any notice.

CORELINE VALVE CO., LTD.

Add: No.210 Xinyuan Road, Ehu Industrial Park, 214116 Wuxi, China

Phone: +86 510 8852 5336

Http: // www.coreline.dk

E-mail : mail@coreline.cn